

FORSTER PRODUCTS

310 E. LANARK AVENUE, LANARK, ILLINOIS 61046 PHONE: 815-493-6360 FAX: 815-493-2371 www.forsterproducts.com

User Instructions for the Original and Classic Case Trimmers

Issue 5

1.0 GENERAL INFORMATION

Brass cases stretch after repeated firings. It becomes necessary to trim them to consistent length for proper chambering and for improved accuracy.

The Original and Classic Case Trimmers are fine, miniature lathes with a superior shell holder design based on a Brown & Sharpe-type collet that provides consistent length, case after case. The staggered tooth, high alloy steel cutter shaft provides fast, smooth, chatterless cutting.

Table 1 provides general Case Trimmer use; however, there are many exceptions. Use our online database to determine which Pilots and Collets are right for the job. Go to forsterproducts.com and click on the **Search** tab. Pilots and Collets for both Case Trimmers are available separately.

Table 1. General Case Trimmer Use

Case Trimmer	Collet Size
Original: trims most standard calibers from 17 caliber to 460 caliber (.459")	#1 through #4
Classic: trims larger and classic black powder calibers	#5 through #8

Note: 17 cal. Cutter Shaft required for 17 cal.

A wide variety of accessories are available for other case conditioning operations (see Section 8.0).

2.0 SAFETY INFORMATION

- Always wear safety glasses.

3.0 PREPARATION

3.1 Case Trimmer Final Assembly (See Figs. 1 and 2)

The Case Trimmer is partially assembled at the factory in order to fit snugly in the package. To finish the assembly, do the following:

- **Classic:** Collet Assembly:

1. Using a slotted screwdriver, remove the slotted screw from the Base which holds the Collet Assembly to the Base. Turn the Collet Assembly around so that the opening is facing the Cutter Shaft.
2. Refasten the Collet Assembly using the same hole and screw.

NOTICE

There is 1/2" of adjustment (in 1/4" increments) built into both Case Trimmers, allowing a trimmer's capacity to be widened before it becomes necessary to use a Long Base (6 1/2"). To adjust, use the outer set of holes on the Collet Housing and Bearing to mount them to the Base.

- **Original and Classic:** Crank Handle assembly:

1. Unscrew the Crank Handle from the Cutter Shaft.
2. Turn the Crank Handle around.
3. Screw the Crank Handle on to the Cutter Shaft.

3.2 General Preparation

- Using the included mounting screws, securely fasten the Case Trimmer to a board (for easy set-up, mounting in a vise and storage) or to a bench. This will ensure both hands are free for the trimming operation.
- Have handy the following items:
 - Reliable manual to consult for correct case lengths.
 - Caliper for checking case lengths.
 - Light oil.
 - Grease.

Figure 1. Case Trimmer Assembly

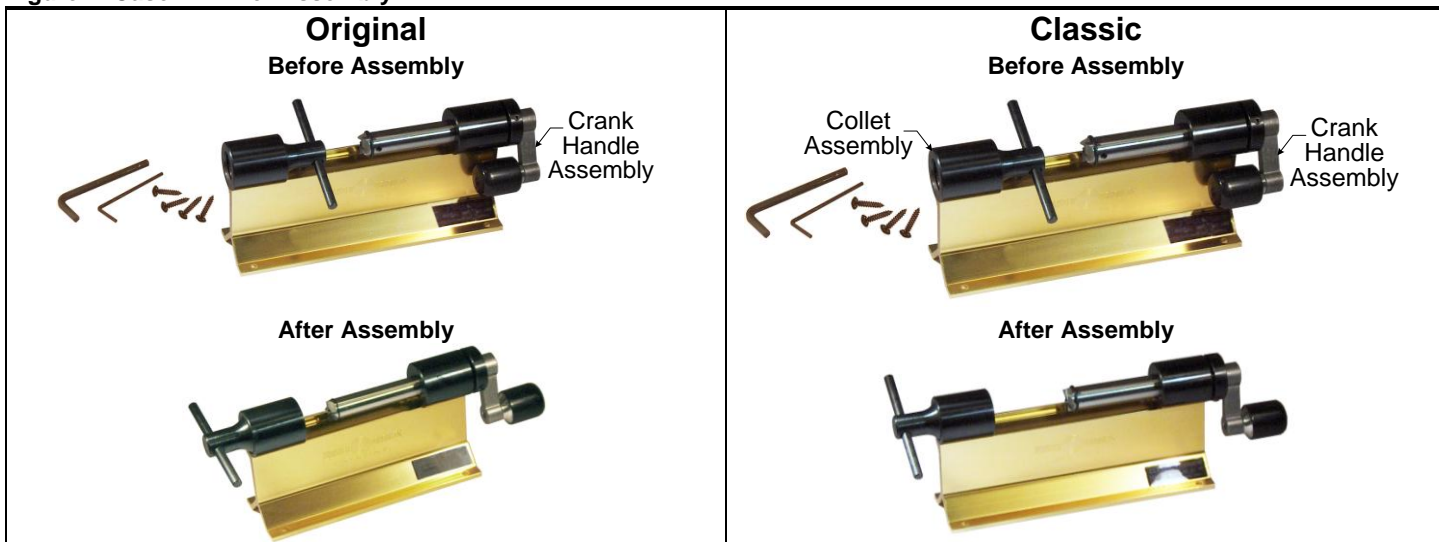
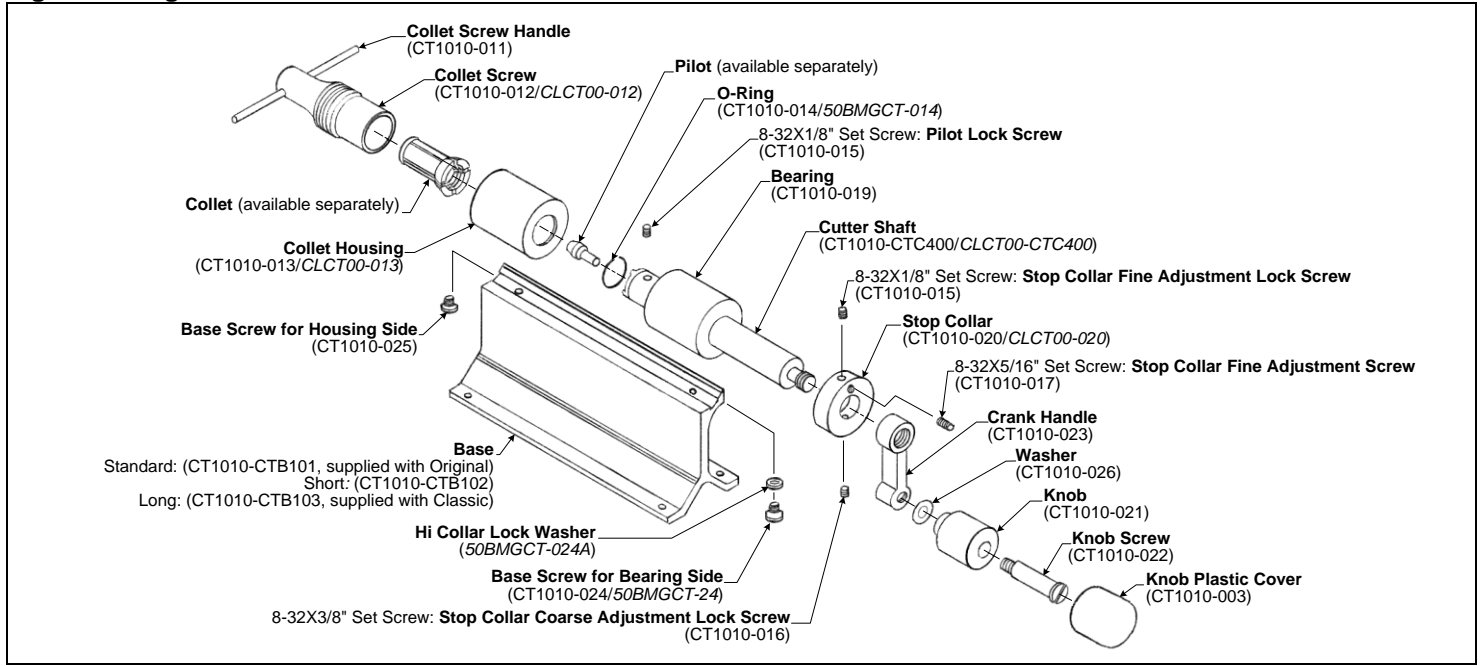

Figure 2. Original and Classic Case Trimmer Nomenclature



Note: Original Case Trimmer order numbers are in regular text, Classic Case Trimmer order numbers are in *italics*. If only one catalog listing is given, it applies to both the Original and the Classic.

4.0 PROCEDURE

4.1 Assemble Pilot and Collet in Case Trimmer

1. Select the correct Pilot and Collet for the case to be trimmed (see Section 1.0).
2. Insert the Pilot into the Cutter Shaft. Press the Pilot firmly against the cutter teeth and lock it in place by tightening the Pilot Lock Screw with the provided 5/64" allen wrench.
3. Remove the Collet Screw from the Collet Housing.
4. Apply a small amount of grease to the Collet front face, tapered portion and base.
5. Insert the Collet into the Collet Screw.
6. Replace the Collet Screw and Collet into the Collet Housing.

4.2 Insert Case and Adjust for Length

1. With tension on the Collet released, insert the base of the case to be trimmed into the Collet.
2. Move the Pilot into the neck of the case. With one hand on the Crank Handle, push the base of the case against the bottom of the Collet. Ensure the base of the case is held firmly against the bottom of the Collet and the Pilot is supporting the inside case neck, then tighten the Collet Screw with the other hand (see Fig. 3).

Figure 3. Case Trimmer with Case Inserted



3. To adjust for case length:

- Set the Stop Collar Fine Adjustment Screw to protrude about 1/32" toward the bearing.
- Slide the Stop Collar toward the Bearing until the Stop Collar Fine Adjustment Screw is in contact with the Bearing.
- Ensure the cutter teeth are in contact with the case neck, then tighten the Stop Collar Coarse Adjustment Lock Screw.

4.3 Make Trial Cut to Check Case Length

1. Turn the Crank Handle to make a trial cut.
2. Remove the case and use a caliper to check its length.
3. Consult a reliable manual for correct case length.

4.4 Make Fine Adjustments for Case Length and Set Stop Collar

1. Turn the Stop Collar Fine Adjustment Screw (one complete turn equals .032") in case length:
 - A clockwise turn increases case length.
 - A counterclockwise turn decreases case length.
2. Once the Case Trimmer is fine-adjusted for case length, lock the Stop Collar Fine Adjustment Screw in place using the Stop Collar Fine Adjustment Lock Screw.
3. Make a final trial cut and check case length. Re-adjust, if necessary.

4.5 Trim Batch of Cases

1. The Case Trimmer is now set up to trim a batch of cases to the exact same length.
2. Occasionally lubricate the Cutter Shaft to Bearing surface with a drop of light oil when trimming.
3. Label and save a master setup case that is trimmed to the correct length for each caliber. This will save setup time in future trimming operations.

5.0 AFTER USE

1. After trimming, a sharp edge will be evident on the case mouth. The inside and outside of this edge should be chamfered with our **Inside-Outside Deburring Tool (DB1000)**.
2. Store the Case Trimmer in a cool, dry location.

6.0 ORDERING INFORMATION

6.1 Collets and Pilots

Collet: Determine your case diameter at its rim. See Tables 2 or 3 and choose the Collet that will accept your case rim. Note: Original and Classic Collets are not interchangeable.

Pilot: Determine your bullet diameter and order the Pilot which is most appropriate. For example, Pilot #30 (CT1030) will handle all rounds that use a .308" diameter bullet, meaning that one Pilot will work for a variety of calibers, including the 30-06, 308, 30 Carbine, 7.62 NATO and 300 Weatherby Mag. Note: Original and Classic Pilots are interchangeable.

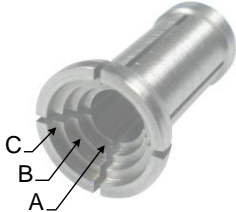
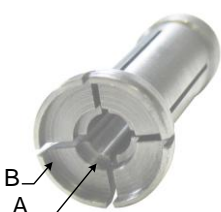
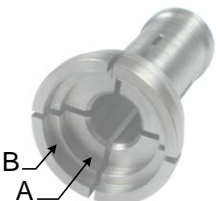

Table 2. Original Case Trimmer Collet Step Dimensions

						
Collet No.	A	B	C	Collet No.	A	B
CT2001 (#1)	.379"	.473"	.532"	CT2004 (#4)	.310"	.605"
CT2002 (#2)	.350"	.418"	.506"			
CT2003 (#3)	.356"	.440"	.545"			

Notes:

- Original Case Trimmers manufactured before June 1, 2010, required a Collet Housing enlargement to .610" when using the #4 Collet; those manufactured after this date already have this modification (see section 7.0).
- #4 Collets manufactured after January 1, 2010, have two steps as shown in Table 2; those manufactured before this date have one step of .605".

Table 3. Classic Case Trimmer Collet Step Dimensions

					
Collet No.	A	B	Collet No.	A	B
CT2005 #5	.584"	.675"	CT2007 #7	-	.640"
CT2006 #6	.545"	.660"	CT2008 #8	-	.610"

6.2 Case Trimmers

6.21 Order Information

Table 4. Original Case Trimmer

Order Number	Description
CT1010	Original Case Trimmer (includes .490" diameter Cutter Shaft; does not include Pilots or Collets)

Table 5. Classic Case Trimmer

Order Number	Description
CLCT00	Classic Case Trimmer (includes .552" diameter Cutter Shaft; does not include Pilots or Collets)

6.22 Kits

Table 6. Original Case Trimmer Kit

Order Number	Description
CTK100	Original Case Trimmer Kit (includes Original Case Trimmer; Collets #1, # 2, #3; Pilots 22, 24, 25, 27, 28, 30)

Table 7. Classic Case Trimmer Kit

Order Number	Description
CLK300	Classic Case Trimmer Kit (includes Classic Case Trimmer; Collets #5, #6, #7; Pilots 458, 505, 510)

6.23 Replacement Parts

Every product component is available individually. A complete list of component order numbers and prices is available on our website. Go to forsterproducts.com, then click on **Components/Parts List**.

7.0 CUSTOM MACHINING SERVICES

A complete list of services, including prices and lead times, is available on our website. Go to at forsterproducts.com, then click on **Custom Machining Services**.

7.1 Original Case Trimmer Collet Housing Enlargement

Use of the #4 Collet requires that the Original Case Trimmer Collet Housing opening be enlarged to .610". This will not affect the use of the #1, #2, or #3 Collet. The Collet Housing can be opened at the factory at no charge. Please return the Collet Housing only. Do not send the entire Case Trimmer.

7.2 Cutter Shaft Resharpener

If the cutter shaft does become dull after years of use of several thousand cases, it can be resharpened at the factory. Please return the Cutter Shaft Only, Do not send the entire Case Trimmer.

7.3 Special Case Trimmer Pilots

Any special size Case Trimmer Pilot within our size range can be ordered through our Resellers or directly through Forster Products. Please specify the exact diameter desired.

8.0 FORSTER PRODUCTS CASE TRIMMER ACCESSORIES

Your Case Trimmer is a versatile tool which can be expanded with the accessories shown in Fig. 4 to perform a variety of case conditioning operations.

Figure 4. Forster Products Case Trimmer Accessories

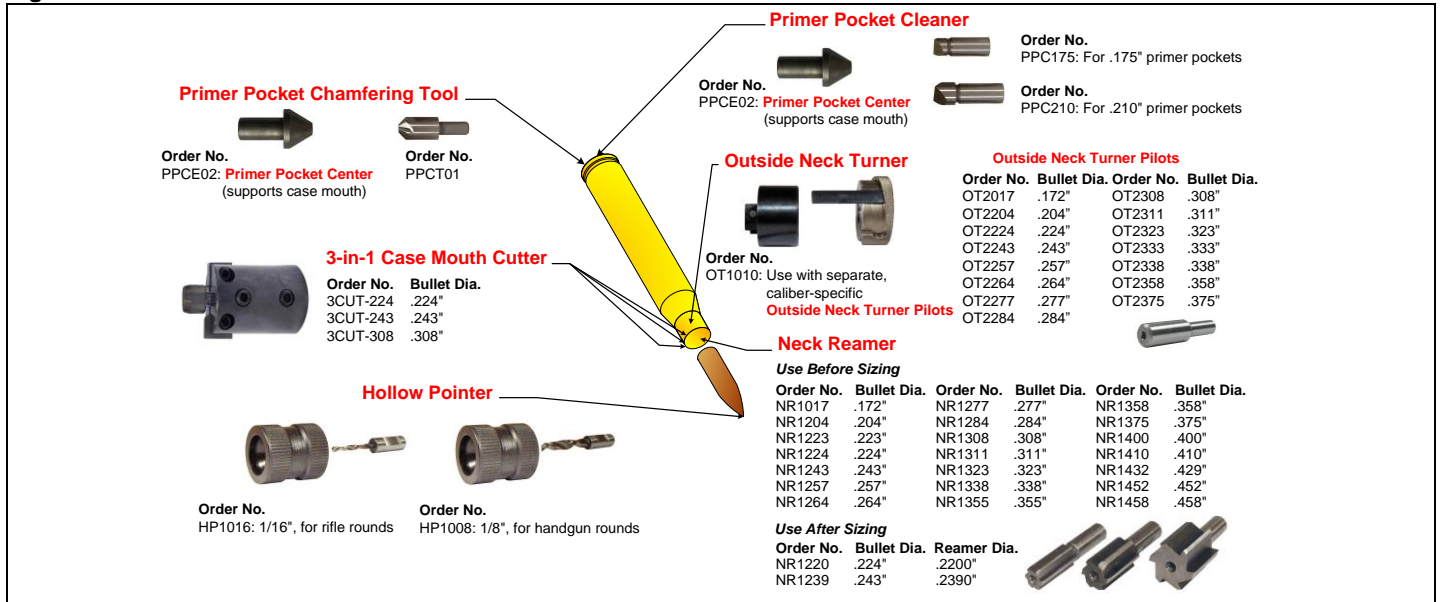

Our **Power Adapter for Case Trimmers (PA1000)** allows your case trimmer to be powered by your electric screwdriver or power drill.

Accessory Name	Function	Used on the Original Case Trimmer (CT1010) and the Power Case Trimmer (PT1010)	Used on the Classic Case Trimmer (CLCT100)
Outside Neck Turner (OT1010)	Removes excess brass from the outside neck wall. When used after case sizing, this process produces neck walls of uniform thickness and exact outside neck diameter. Used after case sizing.	yes	no
Neck Reamer (NR1###)	Removes excess brass from the inside case neck wall, as well as the "dreaded donut" of material that can accumulate after repeated firings. Used before sizing.	yes	yes
3-in-1 Case Mouth Cutter (3CUT-224, 3CUT-243, 3CUT-308)	Simultaneously chamfers the case neck inside and outside diameters, and trims case to length, all in one fast, easy step.	yes	no
Primer Pocket Cleaner (PPC175: for small primer pockets, PPC21: for large primer pockets)	Easily and quickly removes primer and powder residue. Used with the Primer Pocket Center .	yes	yes
Primer Pocket Chamfering Tool (PPCT010)	Chamfers military primer pockets, removing most, if not all, the crimp from military cases. Used with the Primer Pocket Center .	yes	yes
Hollow Pointer (HP1016, HP1018)	Hollow points most calibers of rifle and pistol cartridges in 1/16" and 1/8" size drills. Long and short case trimmer bases are available for hollow pointing long and short cartridges.	yes	yes

We recommend using our Resellers when ordering our products. Their experience and knowledge will help you select the best products that meet your specific requirements. In addition, they usually offer the best prices and convenient delivery options.

To find a Reseller, go to forsterproducts.com, then click on **Locate a Reseller**. If your Reseller cannot supply you, please contact Forster Products directly.

WARRANTY

Forster Products warrants goods of its manufacture against defects in materials and workmanship for the life of the product. Parts which, by nature of their function, are subject to normal wear (such as springs, pins, etc.) and parts which have been altered, abused or neglected, are excluded from the warranty. If the product is deemed defective by workmanship or materials, it will be repaired, reconditioned or replaced (at Forster Products' option). This warranty supersedes all other warranties for Forster Products whether written or oral.

forsterproducts.com

CT1010-002 Issue 5, April 2011